



Marking Card and Marking Software

Our marking software has been designed to meet the needs of all types of users of laser marking systems. The software was developed to be a retrofit package for existing systems, or as original software on new systems. The package provides significant advancements over previous laser marking control systems, while remaining extremely user-friendly. It's an object oriented, graphically interactive, PC control system providing a user the ability define and execute laser marking jobs. Multiple hardware interfaces are supported giving the software the ability to control most Nd:YAG and CO₂ laser marking systems.

Unlike some marking software, the operator never has to remember what fonts and logo's need to be loaded for a particular job. The software automatically performs all required graphic loading. The software does not require users to learn any programming languages or special codes, and yet the software provides all of the flexible, graphic control users are accustomed to, including radial marking, aspect control, character spacing, angular rotations, and full justification. Text to be marked can be fixed or variable. Variable text can be retrieved at runtime from a variety of sources including, the keyboard, a bar code reader, and disk files. Automatic date coding and alphanumeric serialization are included as variable text types. Fonts include laser engraving fonts and Window's True Type fonts. True Type fonts can be vector filled using user specified density, angle and kerf. Graphics (sometimes called "logo's" on other systems) can be imported from a large variety of common vector formats. All graphic features are either menu controlled or graphically controlled via the mouse and keyboard.

The software can create various objects such as barcode, DataMatrix, text, simple geometrical objects (such as line, rectangle, round-corner rectangle, polygon, circle, ellipse etc), complex graphic objects (such as PLT & BMP files), automatic date coding and alphanumeric serialization.

There are three types of marking cards (interface cards) and relevant software: LMS series, LMX series and LMC series.

1. LMS Series Cards and Software

There are following main functions of LMS cards:

- PCI slot card
- DA output resolution: 16 BIT
- D/A output: 2 channels (to control X galvo and Y galvo)
- D/A output voltage: -5V to +5V
- Clock timing: 8MHz
- Digital output: 8 channels, TTL/CMOS compatible
- Digital input: 8 channels, TTL/CMOS compatible
- External input: 4 channels (used for foot switch, detector, replay etc.)
- PWM output: 1 channel (to control laser)
- Relay output: 4 channels



A DB37 connector is used as I/O ports and they are defined as follows:

S/N	Name	Description	Remark
1	+12V	+12VDC of the computer	
2	GND	Ground of the computer	
3	COM1	commonly contact output of the 1st output relay	
4	NC2	normally closed contact output of the 2nd output relay	
5	NO2	normally opened contact output of the 2nd output relay	
6	COM3	commonly contact output of the 3rd output relay	
7	NC4	normally closed contact output of the 4th output relay	

8	NO4	normally opened contact output of the 4th output relay	
9	IN1+	positive pole of the 1stst optical input	
10	IN2+	positive pole of the 2nd optical input	
11	IN3+	positive pole of the 3rd optical input	
12	IN4+	positive pole of the 4th optical input	
13	OUT3	3rd additional output signal 3	
14	OUT1	1st additional output signal 1	
15	X-OUT	X galvo control output	analog
16	Y-OUT	Y galvo control output	analog
17	VCC	+5VDC of the computer	
18	PWM	PWM output. To control pulse repetition rate of YAG laser or laser power and modulation frequency of CO2 laser	TTL
19	VCC	+5VDC of computer	
20	empty	spare	
21	NO1	normally opened contact output of the 1st output relay	
22	NC1	normally closed contact output of the 1st output relay	
23	COM2	commonly contact output of the 2nd output relay	
24	NO3	normally opened contact output of the 3rd output relay	
25	NC3	normally closed contact output of the 3rd output relay	
26	COM4	commonly contact output of the 4 th output relay	
27	IN1-	negative pole of the 1st optical input	
28	IN2-	negative pole of the 2nd optical input	
29	IN3-	negative pole of the 3rd optical input	
30	IN4-	negative pole of the 4th optical input	
31	OUT4	4th additional output signal	
32	OUT2	2nd additional output signal	
33	GND	COM of additional output signals	
34	GND	COM of galvos	
35	GND	COM of laser control signals	
36	FPS	FPS signal	
37	GATE	To control laser beam on/off in YAG lasers	TTL

There are following main functions of LMS marking software:

- Operation under WINXP / 2000
- Acceptable for PLT and BMP
- Support drawing such as circle, rectangle, line etc.
- Support the edit of SHX and TTF fonts
- Barcode, 2D DataMatrix
- Support the layers up to 8
- Save of all system parameters
- Support copy, delete, replace, move etc
- Support mirror, hatch
- Set pulse repetition rate, pulse duty factor
- Control ON/OFF, laser power of CO2 lasers from Synrad, Coherent, Universal Laser s etc

Model and description:

Model	Main function
LMS-1	2D marking to control X galvo and Y galvo
LMS-1A	2D marking to control X galvo and Y galvo plus rotation table
LMS-1AB	2D marking to control X galvo and Y galvo plus XY table

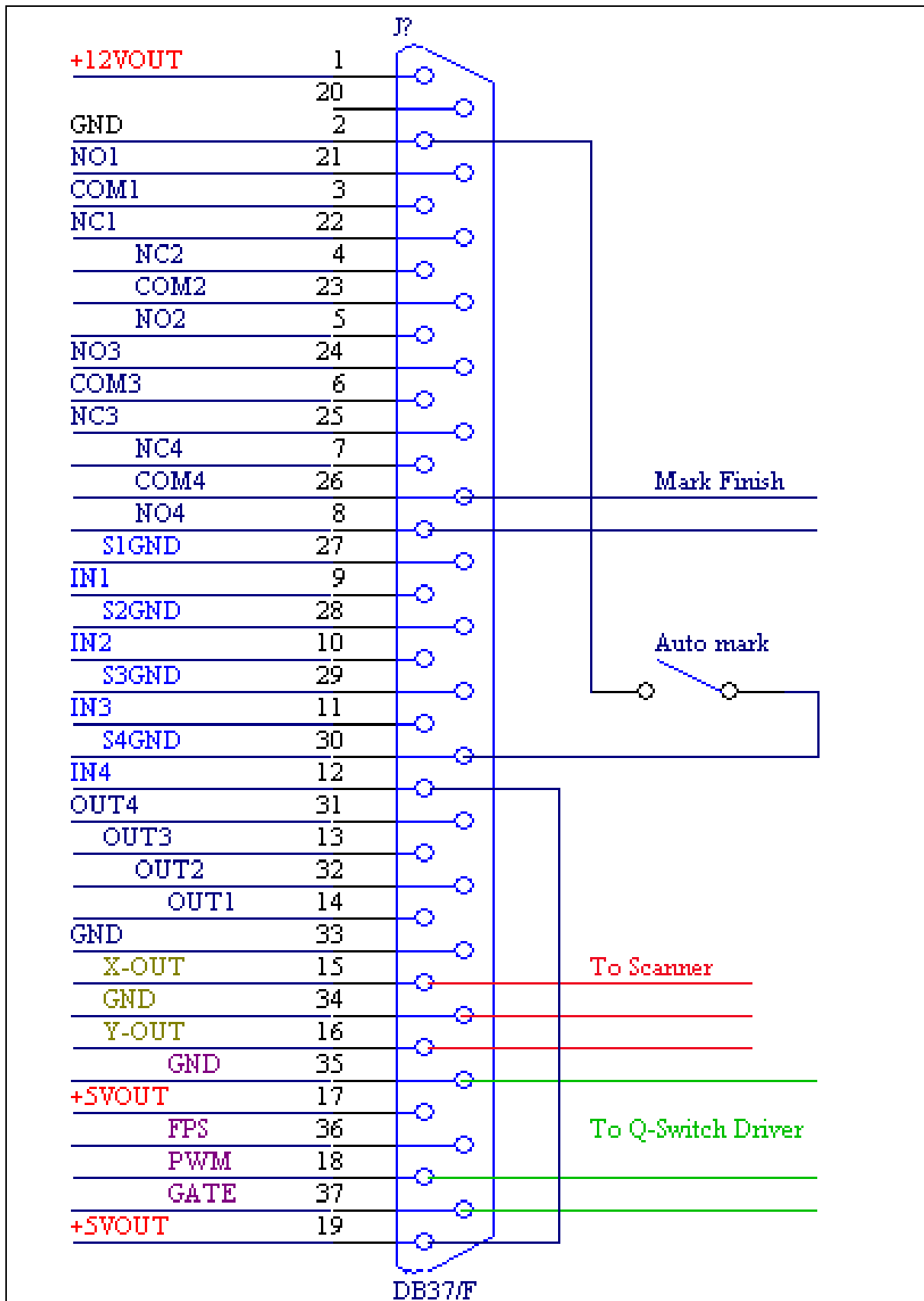

2. LMX Series Cards and Software

LMX Marking Control Card is especially developed for scan head and laser control in real time with a PCI bus interface. It is used with corresponding software to control laser marking.

- 2 analog output ports (for scan head);
- 1 laser switch signal(TTL);
- 1 PWM signal(TTL);
- 9 digit input signals;
- 4 output signals(relay output);
- 2 differential mode axes control for step/servo motor;
- 1 single ended mode axe control for stop/servo motor;

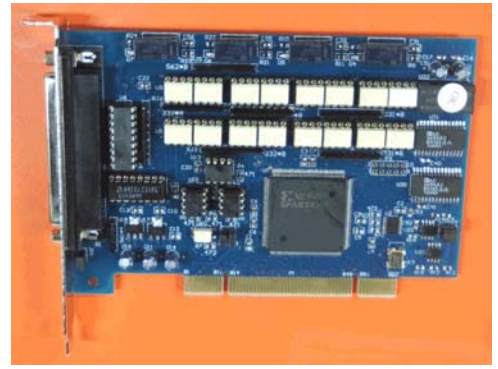

DB37: Pin Assignments

No.	Name	Description	Characteristics
1	CP1+	1 st pulse+ signal	
2	DIR1+	1 st direction+ signal	
3	AGND	Analog GND	Analog
4	X-OUT	Scanning mirror X output	Analog
5	CP2+	2 nd pulse+ signal	
6	CP2-	2 nd pulse- signal	
7	CP1-	1 st pulse- signal	
8	IN0	0 input signal	
9	12V GND	Power 12V GND	
10	5V GND	Power 5V GND	
11	Input 5V	Input 5V	
12	COM1	Relay1 COM	
13	COM3	Relay3 COM	
14	NO4	Relay4 normal open port	
15	NO2	Relay 2 normal open port	
16	IN2	2 input signal	
17	IN6	6 input signal	
18	IN3	3 input signal	
19	IN4	4 input signal	
20	CP3	3 rd pulse signal	
21	DIR3	3 rd pulse signal	
22	PWM	PWM signal	TTL
23	Y-OUT	Scanning mirror Y output	Analog
24	DIR2-	2 nd direction- signal	
25	DIR2+	2 nd direction+ signal	
26	DIR1-	1 st direction- signal	
27	GATE	Laser output signal in YAG laser	TTL
28	5V	Power 5V	
29	12V	Power 12V	
30	IN1	1 input signal	
31	NO1	Relay1 normal open port	
32	NO3	Relay3 normal open port	
33	COM4	Relay4 COM	
34	COM2	Relay2 COM	
35	IN5	5 input signal	
36	IN7	7 input signal	
37	IN8	8 input signal	

Model and description:

Model	Main function
LMX-1	2D marking to control X galvo and Y galvo
LMX-1A	2D marking to control X galvo and Y galvo plus rotation table
LMX-1AB	2D marking to control X galvo and Y galvo plus XY table

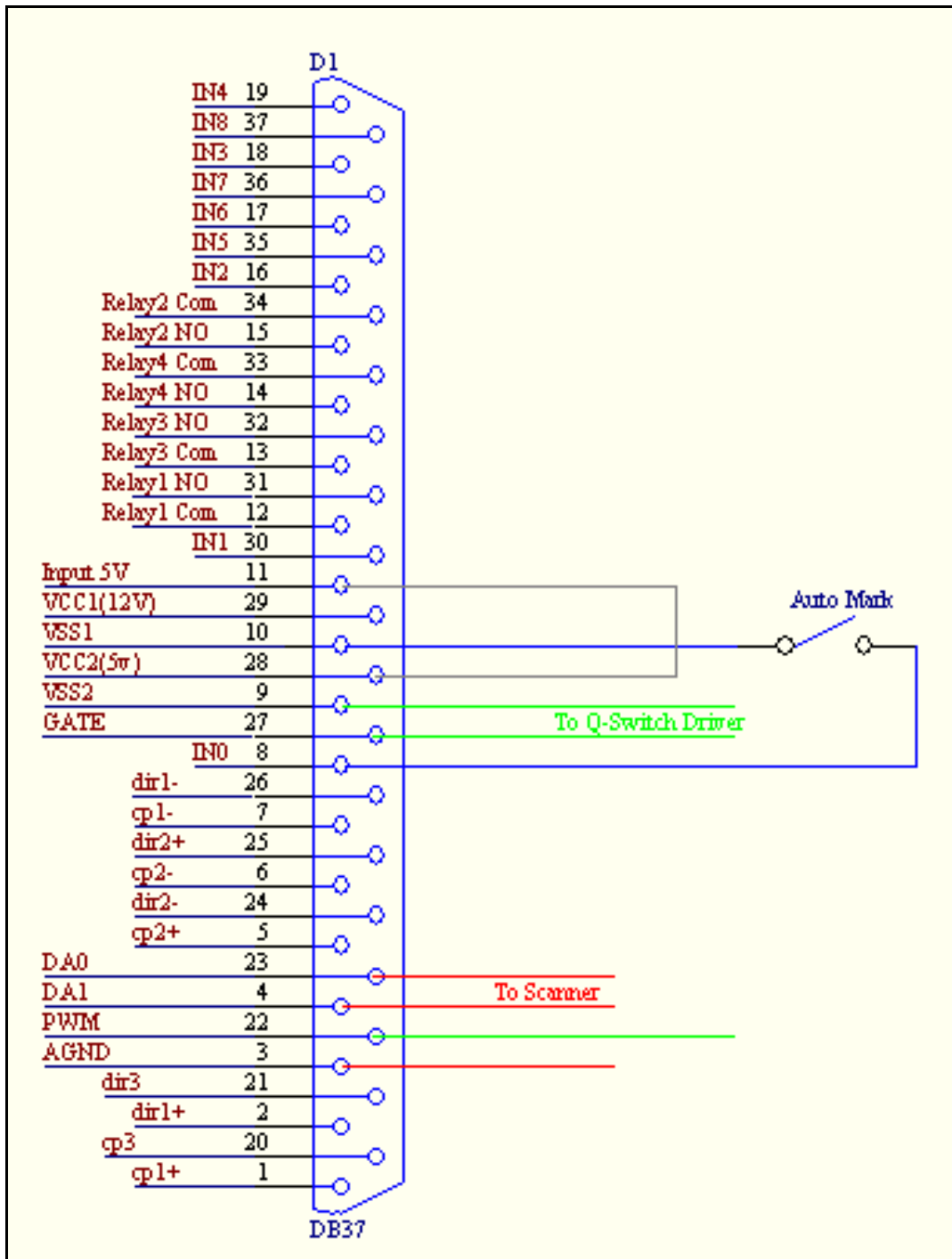

3. LMM Series Cards and Software

LMM Marking Control Card is especially developed for scan head and fiber laser control in real time with a PCI bus interface. It is used with corresponding software to control laser marking. The suitable fiber lasers are IPG, Manlight and SPI lasers via 8-bit laser power adjustment.

- 2 analog output ports (for scan head);
- 11 digital output signals, TTL/CMOS compatible;
- 7 digital input signals TTL/CMOS compatible;
- 1 PWM signal output (TTL).

There are following main functions of LMM marking software:

- Operation under WINXP / 2000
- Acceptable for PLT and BMP
- Support drawing such as circle, rectangle, line etc.
- Support the edit of SHX and TTF fonts
- Barcode, 2D DataMatrix, series numbers, date, time
- Support the layers up to 8
- Save of all system parameters
- Support copy, delete, replace, move etc
- Support mirror, hatch, group
- Set pulse repetition rate, pulse duty factor
- Control ON/OFF, laser power of CO2 lasers from Synrad, Coherent, Universal Lasers, Manlight and IPG etc.

DB37: Pin Assignments

No.	Name	Description	Characteristics
1	CP1+	1 st pulse+ signal	
2	DIR1+	1 st direction+ signal	
3	AGND	Analog GND	Analog
4	X-OUT	Scanning mirror X output	Analog
5	CP2+	2 nd pulse+ signal	
6	CP2-	2 nd pulse- signal	
7	CP1-	1 st pulse- signal	
8	IN0	0 input signal	
9	COM	Relay Comm	
10	GND	GND	
11	NO	Relay NO	
12	D0		
13	D2		
14	D4		
15	D6		
16	NC	Relay NC	
17	Temp	Alarm Temperature	
18	Alarm MO	Alarm MO	
19	Frequency	Alarm Frequency	
20	CP3	3 rd pulse signal	
21	DIR3	3 rd pulse signal	
22	Pulse Repet	Pulse Repe	TTL
23	Y-OUT	Scanning mirror Y output	Analog
24	DIR2-	2 nd direction- signal	
25	DIR2+	2 nd direction+ signal	
26	DIR1-	1 st direction- signal	
27	PA	Power Amplifier(PA)	TTL
28	5V	5V	
29	Red Light	Red Light	TTL
30	IN1	1 input signal	
31	D1		
32	D3		
33	D5		
34	D7		
35	Back Ref	Alarm back reflection	
36	MO	Master Oscillator(MO)	TTL
37	ES	Emergency Stop	TTL

Model and description:

Model	Main function
LMM-1	2D marking to control X galvo and Y galvo
LMM-1A	2D marking to control X galvo and Y galvo plus rotation table
LMM-1AB	2D marking to control X galvo and Y galvo plus XY table

4. LMC Series Cards and Software

Our marking software has been designed to meet the needs of all types of users of laser marking systems. The software was developed to be a retrofit package for existing systems, or as original software on new systems. The package provides significant advancements over previous laser marking control systems, while remaining extremely user-friendly. It's an object oriented, graphically interactive, PC control system providing a user the ability define and execute laser marking jobs. Multiple hardware interfaces are supported giving the software the ability to control most Nd:YAG and CO₂ laser marking systems.

Unlike some marking software, the operator never has to remember what fonts and logo's need to be loaded for a particular job. The software automatically performs all required graphic loading. The software does not require users to learn any programming languages or special codes, and yet the software provides all of the flexible, graphic control users are accustomed to, including radial marking, aspect control, character spacing, angular rotations, and full justification. Text to be marked can be fixed or variable. Variable text can be retrieved at runtime from a variety of sources including, the keyboard, a bar code reader, and disk files. Automatic date coding and alphanumeric serialization are included as variable text types. Fonts include laser engraving fonts and Window's True Type fonts. True Type fonts can be vector filled using user specified density, angle and kerf. Graphics (sometimes called "logo's" on other systems) can be imported from a large variety of common vector formats. All graphic features are either menu controlled or graphically controlled via the mouse and keyboard.

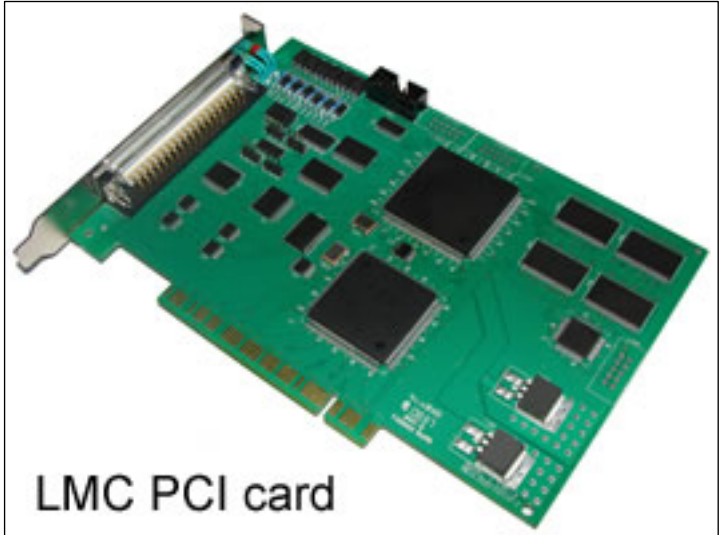

The software can create various objects such as barcode, DataMatrix, text, simple geometrical objects (such as line, rectangle, round-corner rectangle, polygon, circle, ellipse etc), complex graphic objects (such as PLT & BMP files), automatic date coding and alphanumeric serialization.

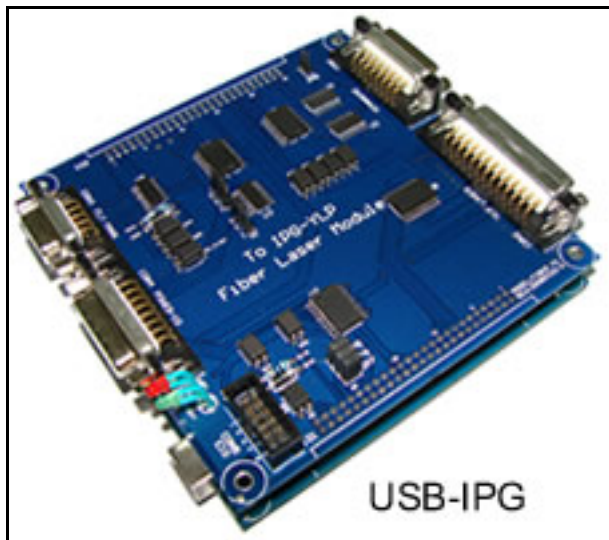
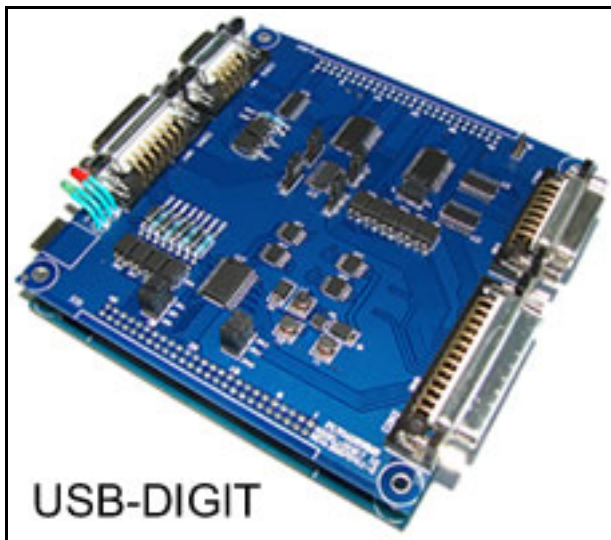

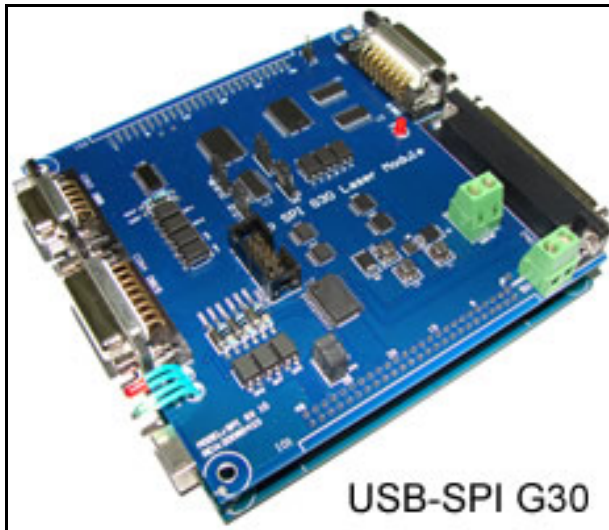

USB-SPI G30

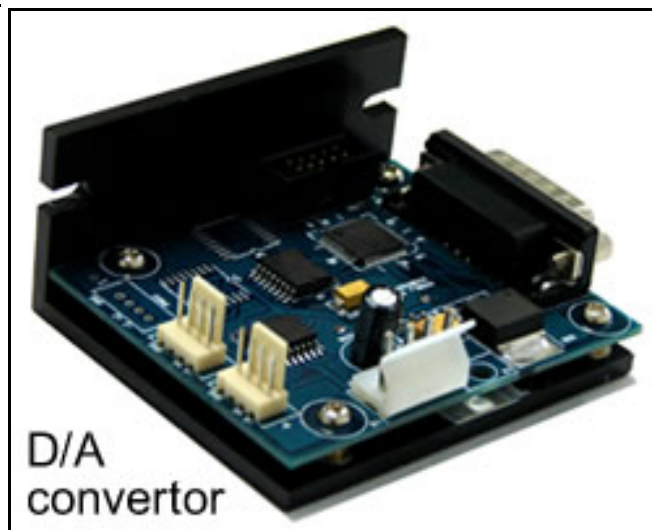
D/A
convertor**Model and description:**

Model	Main function
LMC-5	2D marking to control X and Y analog galvos
LMS-5A	2D marking to control X and Y analog galvos plus rotation table
LMC-5F	2D marking to control X and Y analog galvos plus marking on the fly (fly-marking)
LMC-5AB	2D marking and 2D moving to control X and Y analog galvos plus 2 additional motors (for large field marking using XY table and 2D marking head)
LMC-USB-DIGIT	Digital card, to control X and Y digital galvos plus 2 additional motors.
LMC-USB-IPG	Fiber digital card, to IPG fiber lasers and to control X and Y digital galvos plus 1 additional motor.
LMC-USB-SPI	Fiber digital card, to SPI G3.0 fiber lasers and to control X and Y digital galvos plus 2 additional motors.
LMC-USB-D/A	D/A conversion card, to convert 2 input digital signals into 2 output analog signals , which are used to drive analog galvos.
LMC-USB-ANALOG	Analog card, consisting of USB-DIGIT and USB-D/A.
LMC-USB-IPG-ANALOG	Fiber analog card, consisting of USB-IPG and USB-D/A.
LMC-USB-SPI-ANALOG	Fiber analog card, consisting of USB-SPI and USB-D/A.

A DB37 connector is used in LMC PCI card and their pins are defined as follows:

NO.	Name	Definition	Signal Ref.	Character
1	GND	Ground of computer power supply		
2	ANAPORT2	Analog (Frequency) output [0V-5V]	Ref to GND	Analog
3	FPK	FPK output	Ref to GND	TTL
4	LASER	Laser switch output	Ref to GND	TTL
5	XVOL+	Scanhead output X in-phase [$\pm 5V$]	Ref to GND	Analog
6	GND	Ground of computer power		
7	YVOL+	Scanhead output Y in-phase [$\pm 5V$]	Ref to GND	Analog
8	VCC	+5V of computer power supply	Ref to GND	
9	BPUL-	Extended axis B negative pulse signal	Ref to GND	TTL
10	BDIR-	Extended axis B negative direction signal	Ref to GND	TTL
11	APUL-	Extended axis A negative pulse signal	Ref to GND	TTL
12	ADIR-	Extended axis A negative direction signal	Ref to GND	TTL
13	OUT1	Output control signal No. 1	Ref to EXGND	TTL
14	EXGND	Ground of external 5V power supply		
15	IN3	Input signal No. 3		
16	IN2	Input signal No. 2		
17	S01GND	Ground of IN0 and IN1		
18	IN4	Input signal No. 4		
19	START	External start mark signal		
20	ANAPORT1	Analog (Power) output [0V-9.5V]	Ref to GND	Analog
21	GND	Ground of computer power		
22	PWM	Laser PWM output control signal	Ref to GND	TTL
23	GND	Ground of computer power		
24	XVOL-	Scanhead output X reverse phase [$\pm 5V$]	Ref to GND	Analog
25	YVOL-	Scanhead output Y reverse phase [$\pm 5V$]	Ref to GND	Analog
26	VCC	+5V of computer power supply		
27	GND	Ground of computer power		
28	BPUL+	Extended axis B positive pulse signal	Ref to GND	TTL
29	BDIR+	Extended axis B positive direction signal	Ref to GND	TTL
30	APUL+	Extended axis A positive pulse signal	Ref to GND	TTL
31	ADIR+	Extended axis A positive direction signal	Ref to GND	TTL
32	OUT0	Output control signal No. 0	Ref to EXGND	TTL
33	EX5V	External +5V power supply		
34	S23GND	Ground of IN2 and IN3		
35	IN1	Input signal No. 1		
36	IN0	Input signal No. 0		
37	SSGND	Ground of START and IN4		

There are 4 connectors in LMC USB card and their pins are described as follows:

CON1 (DB15)

Pin No.	Signal name	Illustrations
1,9	CLK-/CLK+	Clock signal. Difference output
2,10	SYNC-/ SYNC+	Synchronized signal. Difference output
3,11	XChannel-/ XChannel+	Digital signal of X axis galvo. Difference output
4,12	YChannel-/ YChannel+	Digital signal of Y axis galvo. Difference output
5,13	ZChannel-/ ZChannel+	Digital signal of Z axis galvo. Difference output
6,14	Status-/ Status+	The state feedback signal of Galvo. Difference input
8,15	Gnd	The reference ground of control card.

CON2 (DB25)

Pins	Signal name	Illustrations
1-8	P0-P7	Laser power. TTL output.
9	PLATCH	Power latch signal. TTL output.
10,11,12,13,14,15,24	Gnd	Control card's Ground
16, 21	SGIN0, SGIN1	Laser status input.
17	Vcc	5V power output of control card.
18	MO	Master Oscillator switch. TTL output
19	AP	Power amplifier. TTL output.
20	PRR	Pulse repetition rate. TTL output.
22	Out2	Laser's red light indication signal. TTL output.
23	EMSTOP	Emergency stop signal. TTL output.
25		NC

CON3 (DB9)

PIN No.	Signals	Illustrations
1	IN8	Common input signal 8. Forms a return circuit with GND 9. To use this signal, connect it and GND respectively to either terminals of power.
2,6	IN 9+ / IN 9-	TTL input signal. Internal 1K current-limited resistor. External current-limited resistor is suggested when voltage is over 12V. Please refer to IN9 Port Illustration.
3, 7	BCODEN/BCODEP	Encoder phase B input signal. Differential input.
4, 5	ACODEN/ACODEP	Encoder phase A input signal. Differential input.
8	Vcc	Control card 5V output.
9	Gnd	Control card Ground. As the return circuit signal of pin 8 & 1.

CON4 (DB15)

PIN No.	Signals	Illustrations
1	SGIN4	Common input signal 4. Forms a return circuit with ground 12 and 13 of the control board. To use this signal, connect it and the ground respectively to either terminal of the power. This is an input signal.
2	EMSTOP	Emergency-stop signal. Forms a return circuit with ground 12 & 13. To use this signal, connect it and the ground signal respectively to either terminal of the NORM-OPEN switch. When this EMSTOP is pressed, it means there is emergency and operation is immediately stopped. The signal is an input signal.
3	POW_BTN	Power signal of the laser instrument main power source. Forms a return circuit with the Ground 12 & 13 of the control board. To use this signal, connect it and the Ground signal respectively to either terminal of the NORM-OPEN switch. When the power button is pressed downward, pin 10 & 11 are connected; when the button is bounced upwards, they are disconnected. For the power connection, see "Power Connection". This is an input signal.
4,5	VCC	5V input power positive terminal. This is an input signal.
8	START	Start signal. Forms a return circuit with Ground 12 & 13. To use this signal, connect it and the Ground signal respectively to either terminal of the power. This is an input signal.
9	OUT0	Common output signal 0. Uses GND 12 & 13 signals as reference signals. This is an output signal.
10,11	POW_CON,P OW_CON1	Connection port of power relay. Connect POW_CON to the anode of power relay's control power. One of the power relay's control ports should be connected with POW_CON1, and the other to the cathode of the cathode of power relay's control power. When the 3-point power is plugged in, POW_CON and POW_CON1 are connected. At that time, power relay's control port is connected to its control power, power relay picks up, and fiber laser main power is on. Please see "Power Connection" for reference.
12,13	Gnd	5V input power cathode (Ground signal), i.e. the control card's Ground

		signal. This is an input signal.
6,14	DIR-/DIR+	Output signal. Direction signal of the extend axis (step motor or servo motor). The output mode could be set up either as differential output, or as level output (TTL output). This is an output signal.
7,15	PUL-/PUL+	Pulse signal of extend axis (step motor or servo motor). The output mode could be set up either as differential output, or as level output (TTL output). This is an output signal.

The marking software is always being improved and modified from time to time. The actual software characteristics may change a little.