

# QSD Series Q-Switch Driver Operation Manual



**Sintec Optronics Pte Ltd**

50 Bukit Batok Street 23 #07-15

Midview Building, Singapore 659578

Tel: +65-67781866 Fax: +65-65152908

E-mail: [sales@SintceOptronics.com](mailto:sales@SintceOptronics.com) or [sales@sintecoptronics.com.sg](mailto:sales@sintecoptronics.com.sg)

URL: <http://www.SintecOptronics.com> or <http://www.SintecOptronics.com.sg>

QSD series AO Q-switch drivers are specially designed for driving various AO Q-switches. It includes series models such as QSD-2750, QSD-2775 and QSD-27100.

## 1. Principle of Q-switching Technology

The acousto-optical Q-switch often used in the laser marking makes use of mutual interaction between an ultrasonic wave and a light beam in a scattering medium. The light beam that enters in a direction forming a Bragg angle to the wave surface of the acoustic wave in the scattering medium is diffracted in accordance with periodic changes in the diffraction rate produced by the acoustic wave.

The situation is briefly explained in Figure 1. First of all, an RF signal is impressed to the transducer adhered to the molten quartz and thickness extensional vibration is produced. Ultrasonic shear waves are caused to advance in the molten quartz by this vibration, and phase grating formed by acoustic waves is produced. The laser beam is diffracted when it satisfies the Bragg angle with respect to this phase grating, and is separated in space from the incident light.

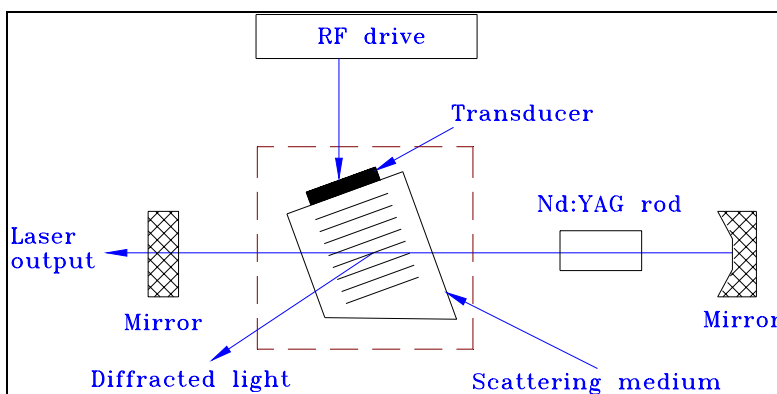

Fig. 1: Principle of A-O Q-switch

If the laser optical resonator is constructed against 0-dimensional diffracted light (undiffracted light), the diffracted light deviates from the laser optical resonator axis when a RF signal is impressed. As a result, loss occurs in the laser optical resonator and laser oscillation is suppressed. To make use of this phenomenon, an RF signal is impressed for a certain length of time only (status of low Q-value) to suspend laser oscillation. In the meantime, the population inversion of the Nd:YAG rod is accumulated by continuous pumping. When the RF signal is reduced to zero (status of high Q-value) and the loss to the laser optical resonator is removed, the accumulated energy is activated as laser oscillation in a pulse form within an extremely short length of time. They are Q-switch pulses.

This situation is briefly explained in Figure 2. When an RF signal is subjected to pulse modulation, it is possible to periodically take out a Q-switch pulse. When the period of Q-switch pulses becomes shorter than the life (about 200  $\mu$ s) of the higher order of the Nd:YAG rod, however, the population inversion decreases and the peak value of Q-switch pulses decreases.

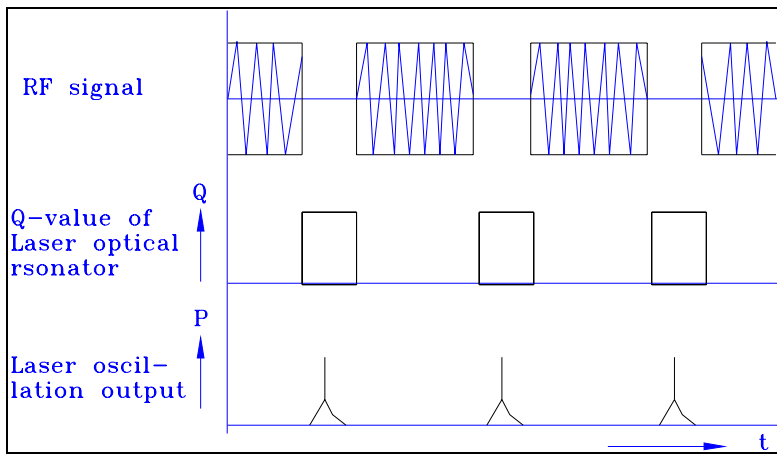

Figure 2: Laser oscillation output of a Q-switch laser

## 2. Specifications of Q-switch Driver

A high power RF driver module is available in output powers of 50W, 75W or 100W. Powered from 220VAC or 110VAC, the modulation inputs allow either full digital control or activation of an internal pulse generator. First pulse suppression(FPS) is automatically implemented.

### Main Specifications:

RF power output: 50W, 75W or 100W

Frequency: 27.125MHz

VSWR:  $\leq 1.2:1$

Modulation repetition rate: 800Hz-50kHz

First pulse suppression

Modulation control inputs: digital TTL

Driver over-heat, Q-Switch over-heat

Internal over-temperature protection and over-current protection

Digital display of frequency

Supply voltage input: 220VAC/110VAC, 50Hz/60Hz, <150W



### Model Numbers:

QSD-2750 (50W), QSD-2775 (75W) or QSD-27100 (100W)

### Dimension:

19" 2U frame, 483×88×270mm

## 3. Description of Q-switch Driver

The driver consist of 5 modules, that is DC power supply, RF power, control system, control panel and I/O ports.

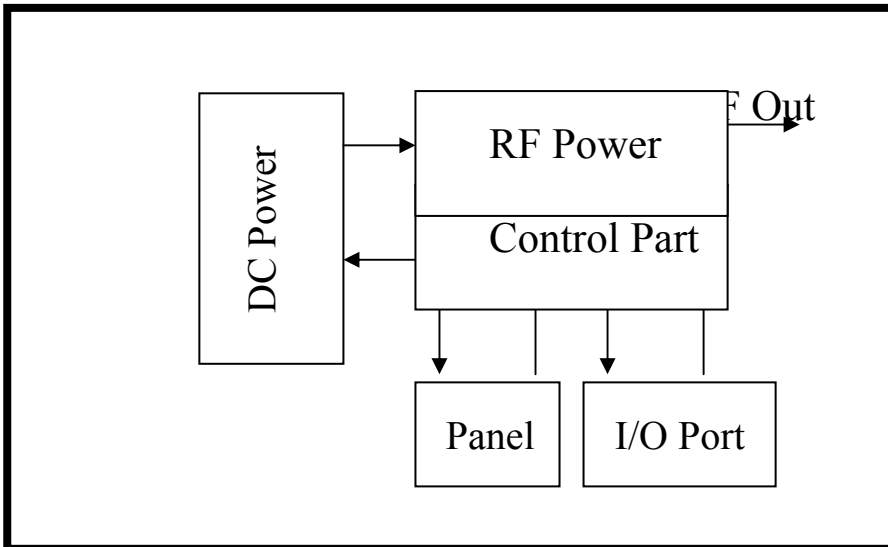

Fig. 3 Composition of the driver

### 3.1 Control Selection

#### 3.1.1 M1 Control

It is a control with Q modulation function and first pulse suppression function. During the laser beam control signal is valid, the modulation signal will be automatically added to the RF signal. The period of the modulation signal is T2, laser beam on is T3, the fall time of first pulse suppression signal is T1. In general, the pulse modulation period can be changed by adjusting the frequency potentiometer on the control panel.

The setting in the factory is: T3=5us, T1=150us. When changing T2, there are no changes of T1 and T3. In general, the user does not need to change these settings.

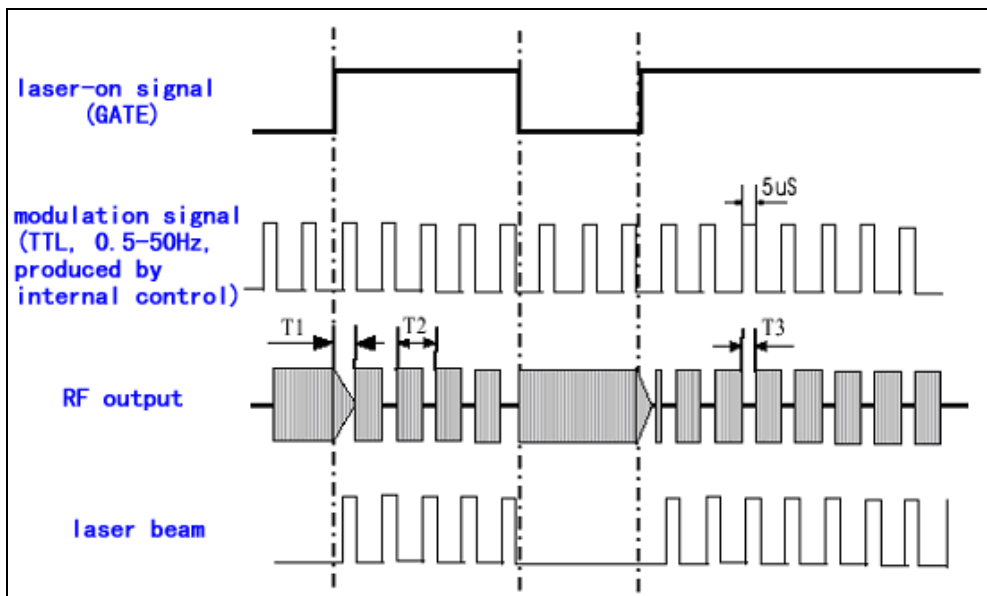

Fig. 4 Time sequence of M1 control (laser on at high level TTL)

### 3.1.2 M2 Control

It is not often used.

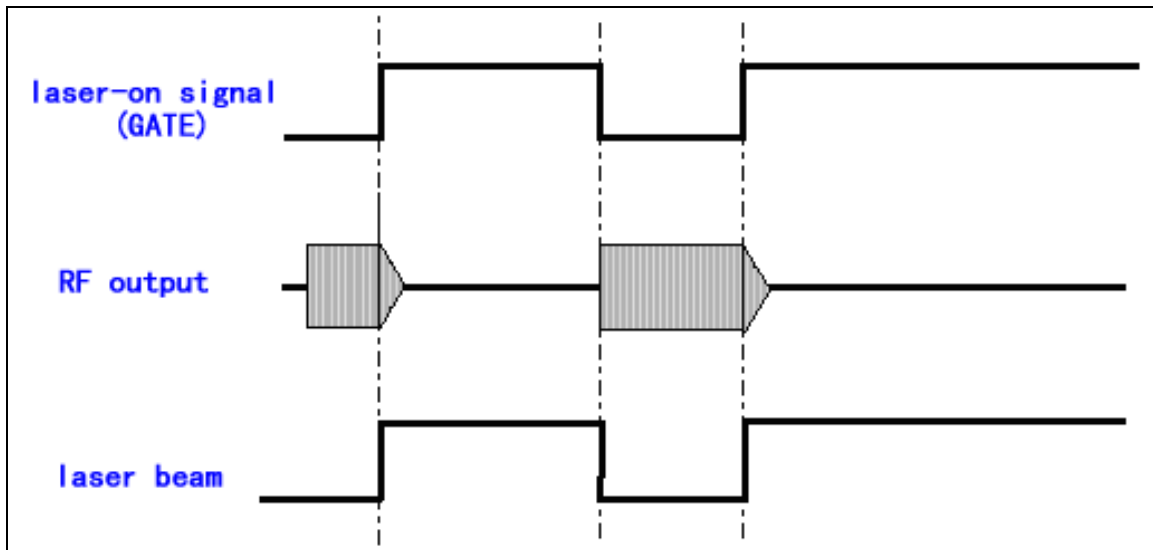

Fig. 5 Time sequence of M2 control (laser on at high level TTL)

### 3.2 Alarm

When there is over heating inside the driver, the ALARM indicator will be on and the RF output will be stopped.

### 3.3 Level Selection

Whether the laser is on at high or low level depends on the selection of LEVEL switch. When set to LOW, the laser beam is on when GATE is high level TTL. When set to HIGH, the laser beam is on when GATE is low level TTL.

### 3.4 I/O Ports

The PINs are defined as follows:

- PIN1: COM of external indicator
- PIN2: + signal of external red indicator
- PIN3: + signal of external green indicator
- PIN4: TTL, +, external frequency control input
- PIN5: TTL, ground (COM), external frequency control input
- PIN6: external voltage (conversion from voltage to frequency), ground (COM)
- PIN7: external voltage (conversion from voltage to frequency), 0-5V, + (suggest not to use)
- PIN8: laser-on signal, TTL, ground
- PIN9: laser-on signal, TTL, +

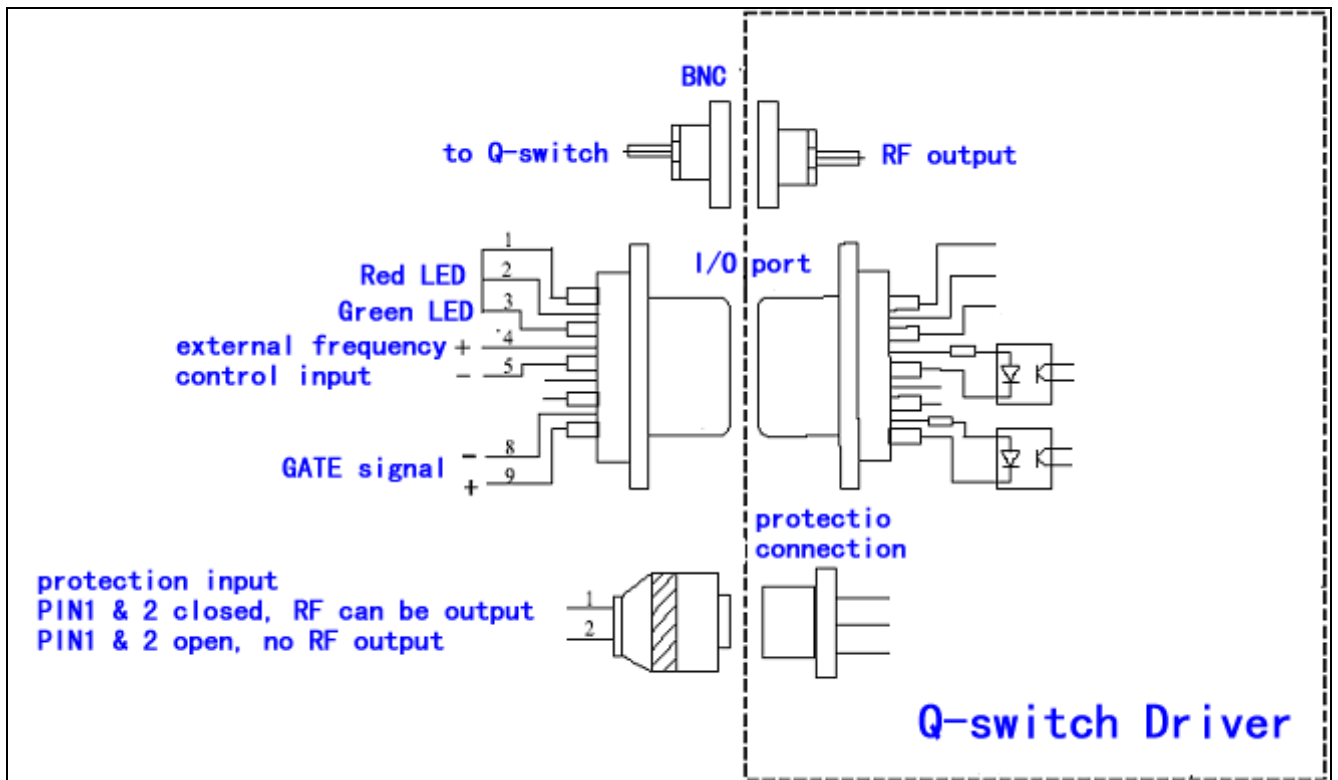

Fig. 6 I/O ports

### 3.5 Control Panel

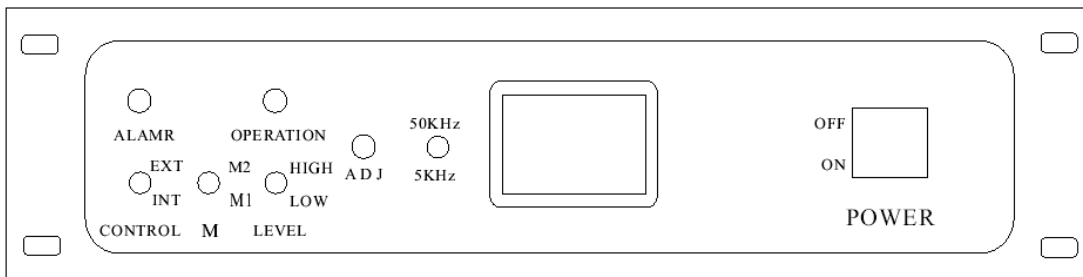

Fig. 7 Control Panel

- CONTROL: INT: internal frequency modulation
- EXT: external frequency modulation
- M:       M1: M1 control method
- M2: M2 control method
- LEVEL:   LOW: the laser beam is on when GATE is high level TTL
- HIGH: the laser beam is on when GATE is low level TTL
- OPERATION: green LED is on when operation
- ALARM:   red LED is on when there is problem.
- ADJ:      adjusting frequency
- POWER:   main power switch (default is 220VAC)
- Display:   frequency

## 4. Installation

- 1) There should be a good ventilation condition around the driver.
- 2) The driver should be well grounded from the back of the driver.
- 3) BNC cable should be 50ohm.
- 4) The input electricity is 220VAC.
- 5) Refer to Fig. 6 to connect relevant wires.
- 6) Please pay attention to PROTECTION INPUT. In general, it is connected to the signal which comes from a part to be protected. If there is no protection related, just short-connect it.

## 5. Operation

- 1) Connect all the wires.
- 2) Please confirm that the Q-switch is water-cooled. Then turn on the main power from the control panel.
- 3) Internal Control: please use the following setting to switch off laser beam:  
CONTROL---INT; M---M1; LEVEL---LOW
- 4) Based on the above setting, change LEVEL to HIGH and the driver is in waiting status. RF with modulation is output to control Q-switch. Adjusting the frequency potentiometer to change the frequency. If the driver is OK, then change LEVEL to LOW for your use.
- 5) External Control: connect I/O ports accordingly. Set CONTROL to EXT and LEVEL to LOW and external input high level TTL will control the driver. In this case, green LED will flash. External frequency is from 0.5kHz to 50kHz and their pulse width is from 3us to 20us.

## 6. Trouble Shooting

Phenomenon	Potential reasons	To do
No power indicator, fan does not turn	<ul style="list-style-type: none"> <li>● AC220VAC not given</li> <li>● Output may be shorted</li> </ul>	Connect cable well
ALARM on	<ul style="list-style-type: none"> <li>● Over heating inside</li> <li>● Protection input is open</li> <li>● Connection between Q-switch and driver not well</li> </ul>	<ul style="list-style-type: none"> <li>● Improve ventilation</li> <li>● Check the protection input</li> <li>● Measure VSWR</li> </ul>
Operation LED is on but no RF output	<ul style="list-style-type: none"> <li>● Whether GATE signal is valid</li> <li>● LEVEL or CONTROL not set tight</li> </ul>	<ul style="list-style-type: none"> <li>● Check GATE</li> <li>● Use right setting</li> </ul>
Marked words wrong	LEVEL setting wrong	Set again

## 7. Accessories

1pcs, cable

1pcs, protection connector

1pcs, D9 connector

## Sintec Optronics Pte Ltd

We, Sintec Optronics Pte Ltd, are a Singapore-based supplier of a wide range of photonics products (lasers & parts, optical components, and relevant accessories). We provide various high-quality low-price lasers, parts & optics for OEM and end users. The company is managed by experienced professionals with engineering & servicing backgrounds. Our customers range over 32 countries around the world.

### 1. Lasers & Machines

- 1.1 Sealed CW CO2 lasers
- 1.2 CW Nd:YAG laser systems
- 1.3 Diode-pumped YAG lasers
- 1.4 Diode pumped green lasers
- 1.5 Pulse Nd:YAG lasers
- 1.6 High-power diode lasers
- 1.7 Red diode lasers
- 1.8 Diode-pumped green lasers
- 1.9 Laser cutting machines
- 1.10 Laser marking machines
- 1.11 Laser engraving machines

### 2. Optical Components

- 2.1 Focusing lenses
- 2.2 Mirrors & output couplers
- 2.4 Beam expanders
- 2.5 Zoom beam expanders
- 2.6 Beam splitters
- 2.7 Scan mirrors
- 2.8 Scan lenses (f-theta lenses)

### 3. Accessories

- 3.1 Laser lamps (Kr and Xe lamps)
- 3.2 CW and pulse Nd:YAG laser power supply
- 3.3 Diode laser drivers
- 3.4 Laser chillers/heat exchangers
- 3.5 Laser crystals & optical crystals (YAG rods, KTP, BBO, ZnSe etc)
- 3.3 AO Q-switches & drivers
- 3.4 Laser power/energy meters
- 3.6 Laser safety goggles
- 3.7 Optical scanners/galvanometers
- 3.8 Motorized or manual adjustable XYZ stages & rotary stages
- 3.9 Vertical translation stages
- 3.10 Tilt stages
- 3.11 Linear translation stages
- 3.12 Mirror mounts, holders, posts & holders
- 3.13 Optical tables
- 3.14 Magnetic bases, rails
- 3.15 CNC control software
- 3.16 Laser marking heads and marking software
- 3.17 Laser pump chambers

We are a leading company in Singapore to provide quality laser systems & optical components and excellent services at attractive prices. We always try our best to make our products reliable, safe, easy to use, flexible and economical. We believe our continuing advances in technologies will make us the best choice to provide the solutions to make you remain competitive and be a leader in your own field.