

CO2 Laser Controller

# Operation Manual



**Sinterc Optronics Pte Ltd**

50 Bukit Batok Street 23 #07-15

Midview Building, Singapore 659578

Tel: +65-67781866 Fax: +65-65152908

E-mail: [sales@SintercOptronics.com](mailto:sales@SintercOptronics.com) or [sales@sintercoptronics.com.sg](mailto:sales@sintercoptronics.com.sg)

URL: <http://www.SintercOptronics.com> or <http://www.SintercOptronics.com.sg>

CO2 laser controller provides DC power supply, control I/Os and laser power adjustment. Its main specifications are

- Model: STCB28-xxxx (xxxx: CO2 laser model such as ULR10, ULR50 etc)
- Provide DC power supply according to the lasers (ULR10, ULR30, ...)
- Laser power adjustable from 0 to 100% of the maximum laser power
- Two control methods available: manual and auto
- Under the manual method, a potentiometer on the panel is used to adjust the laser power and a button is used to switch on/off laser beam
- Under the auto method, external signal TTL is used to adjust laser power, laser pulse repetition rate and laser beam on/off



## 1. Description of Front Panel

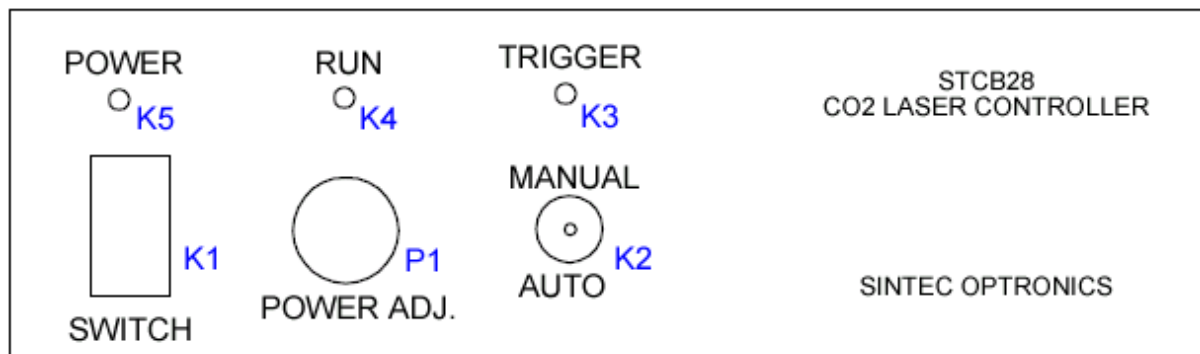

K1: main switch. Turn on/off electricity input.

K2: to select manual or auto control. “manual control” means that the output laser power is adjusted by P1 and laser beam on/off is controlled via pressing K3. “auto control” means that the laser power and beam on/off is controlled via TTL signal from DB9 on the rear panel.

K3: button for beam on/off. When K2 is turned to “manual”, pressing K3 button is beam on.

K4: laser beam indicator

K5: main power indicator

## 2. Description of Rear Panel

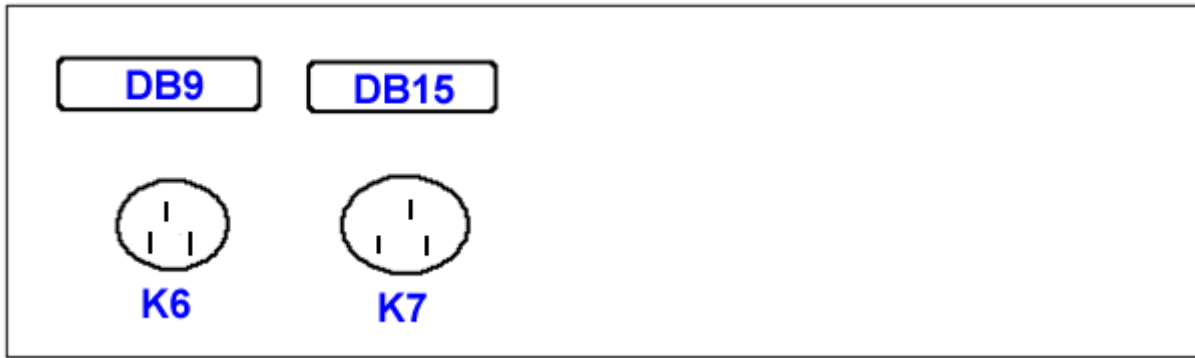

K6: electricity input 220VAC, 50Hz. PIN1 (phase), PIN2 (neutral) & PIN3 (ground).

K7: empty (no connection).

Remark: if there is a DC power supply of the CO2 laser inside the controller, K7 is the DC power output to laser. Here it is 48VDC. PIN1 (+) & PIN2 (COM)

DB9: control input.

PIN1: "GATE" signal input and turn on/off laser beam.

Remark: it is not used in most cases.

PIN3: "PWM" signal input to adjust output laser power.

PIN5: "COM" of the above signals.

PIN6 & PIN9: to foot switch: the laser beam is on when it is short and the laser beam is off when it is open.

DB15: output signals

PIN4: "PWM" signal to laser to adjust laser power and turn on/off laser beam.

PIN12: "COM" of "PWM" signal

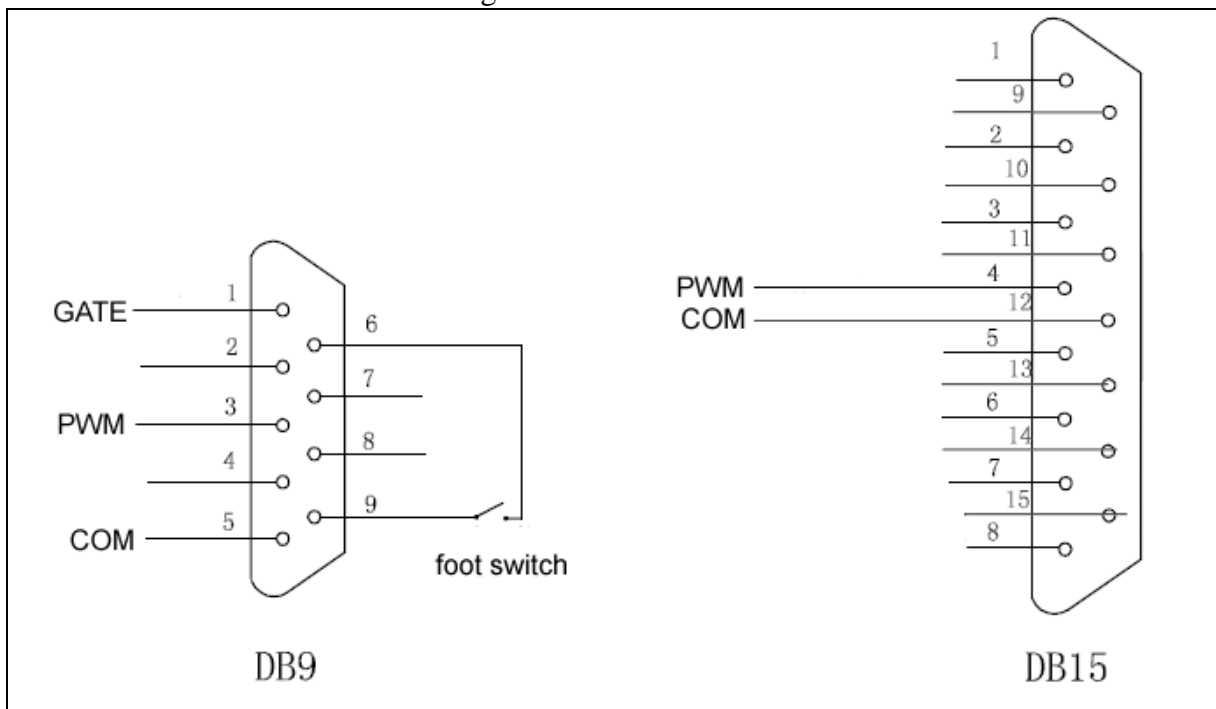

## 3. Operation

1. When K2 is turned to MANUAL, the laser beam is on when pressing TRIGGER. You can adjust the laser power by rotating P1. If GATE is given through external signal, "high

level” of the signal outputs laser beam and the power can be adjusted via P1 but TRIGGER is invalid.

2. When K2 is turned to AUTO, the laser power and beam on/off is controlled via PWM (or TTL). If the laser is made by Universal Laser Systems, the power change depends on the pulse width as follows:

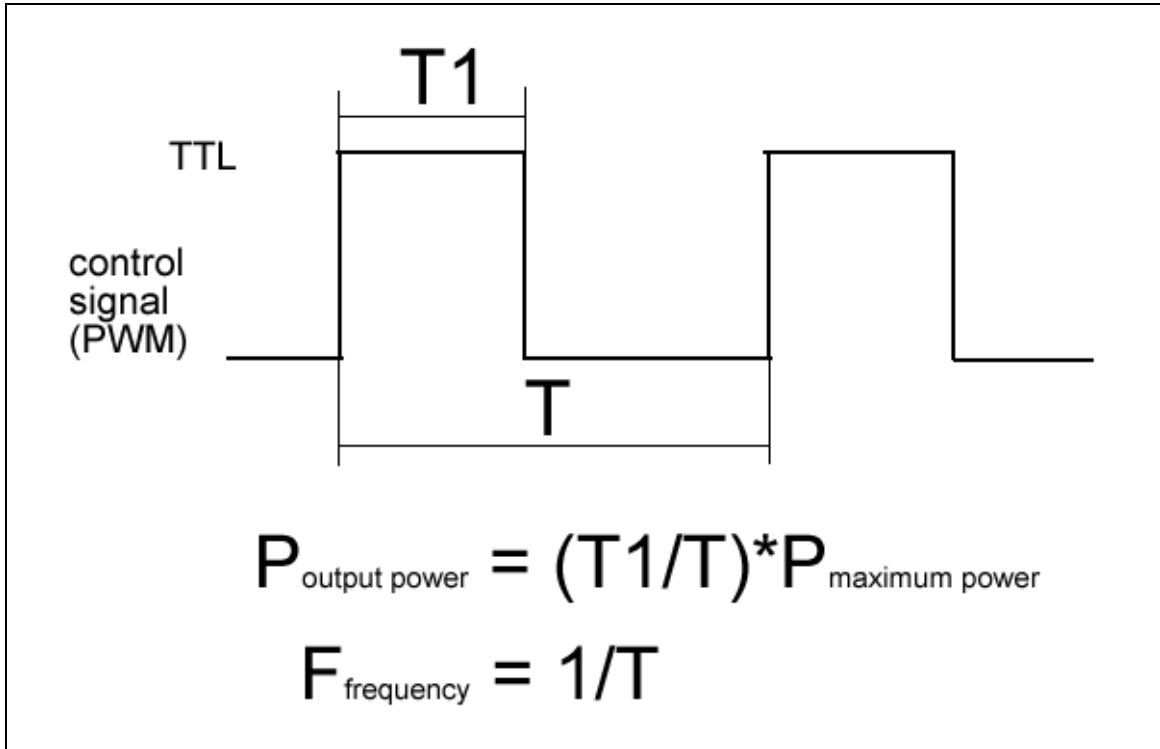

In our controller, the frequency is fixed at 5kHz (0.2ms). Adjusting the output laser power means adjusting pulse width T1.

#### 4. Trouble Shooting

In order to check whether the control is normal, you just do:

- 1) If there is a DC power supply of the CO2 laser inside the controller, the output voltage of K7 using a multi-meter to check whether it is 48VDC.
- 2) To measure the waveform of PWM using an oscilloscope. It is a square waveform at 5kHz. When you adjust POWER ADJ, the pulse width will change.

If you can not watch the waveform of PWM, you may use a 5VDC directly to laser to see whether you can get a laser beam as described in page 5.

If you use Universal laser, the connections are shown as follows:

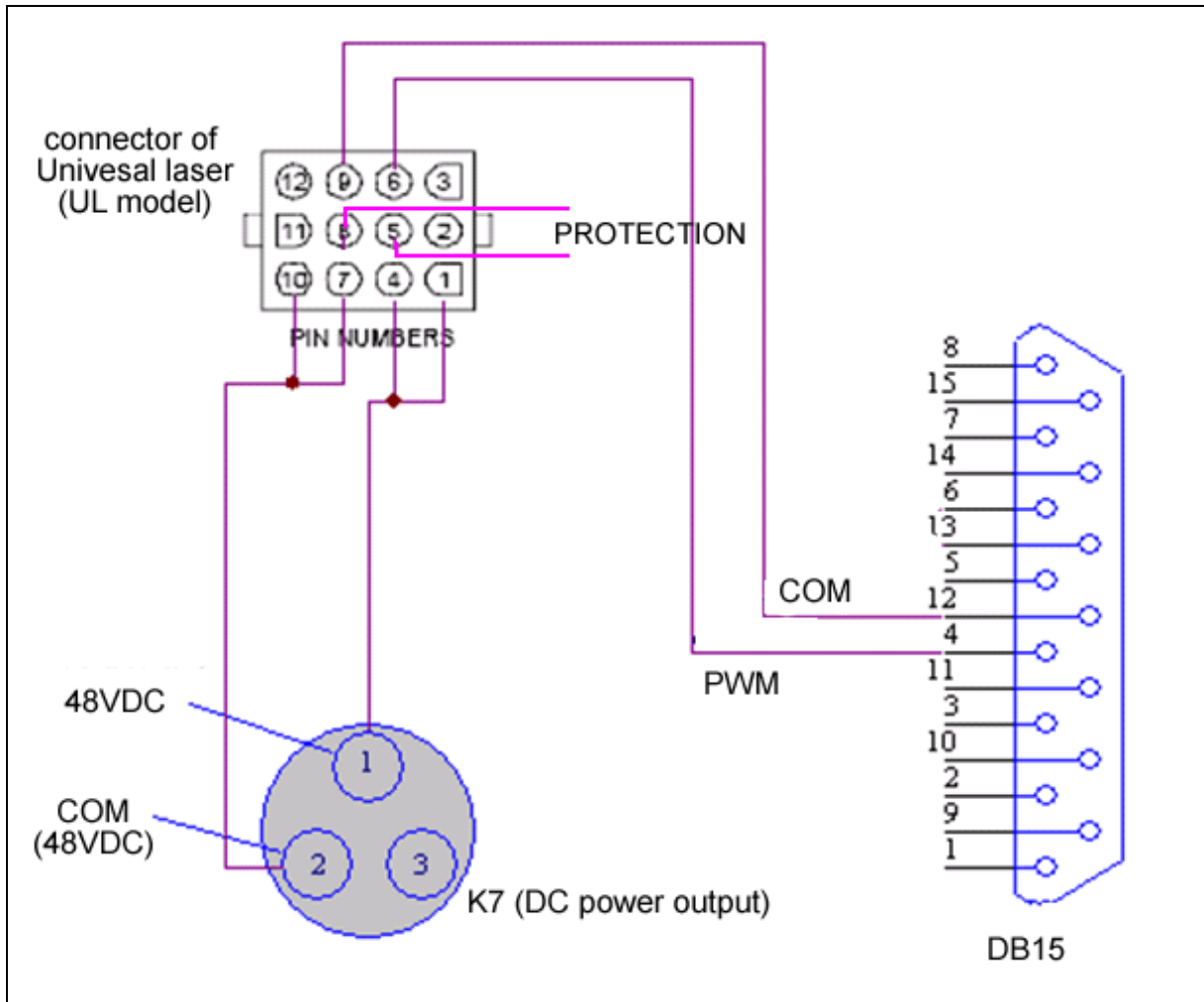

**Remark:** PROTECTION of the connector of the laser should be shorted for laser beam out. If it is open, there is no laser beam.

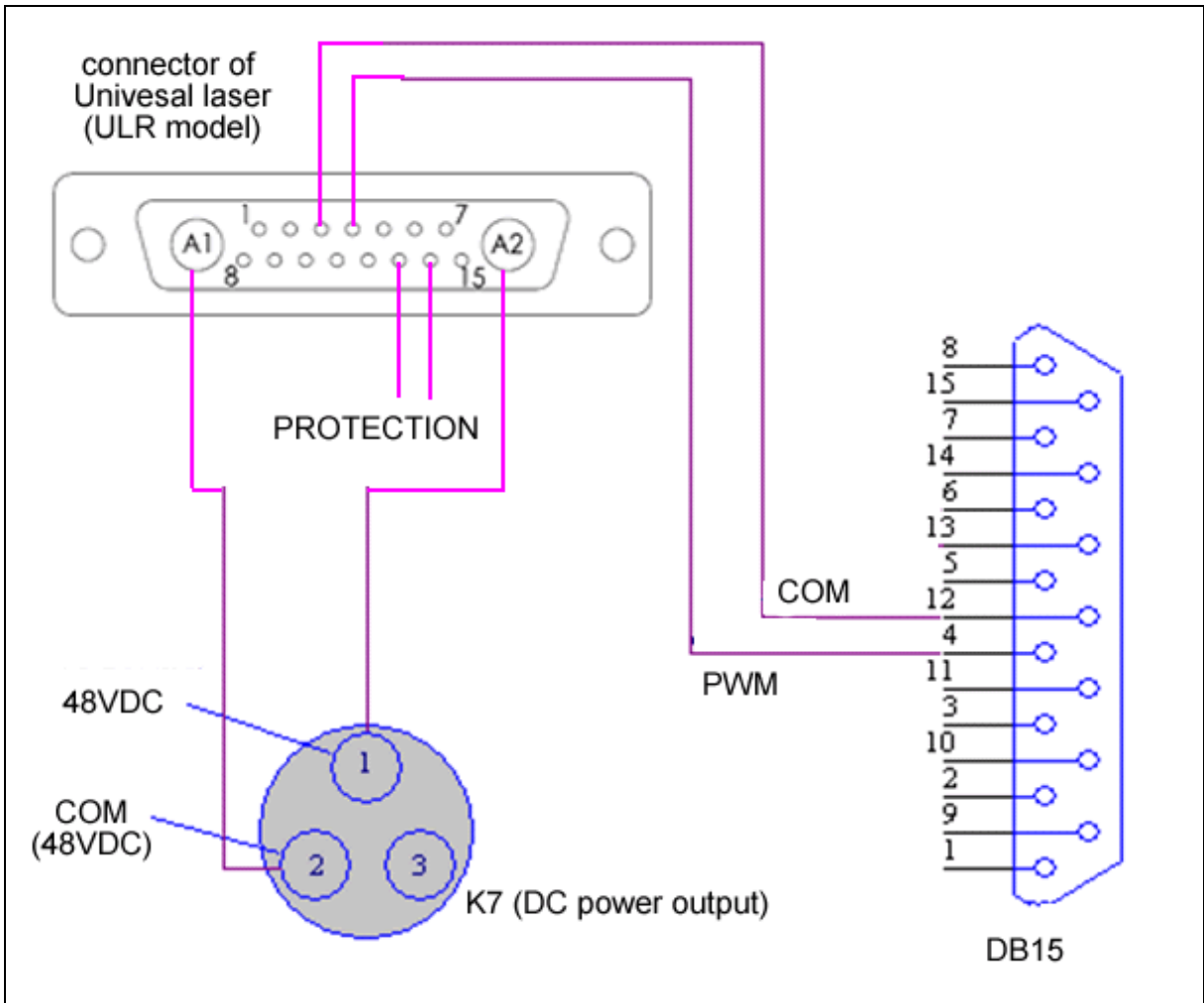

**Remark:** PROTECTION of the connector of the laser should be shorted for laser beam out. If it is open, there is no laser beam.

If you want CW laser beam, you may use a 5VDC signal instead of PWM to make laser beam on continuously. You may also get 5VDC from PIN3 of the potentiometer or PIN20 of IDC20 inside the controller. Please note that you need to have some control signal to switch on/off the laser beam (for example, you may use a relay to switch on/off this 5VDC connection). Otherwise, the laser beam will be always on.

If the customer uses our LMS series D/A cards, the connection should be as follows:

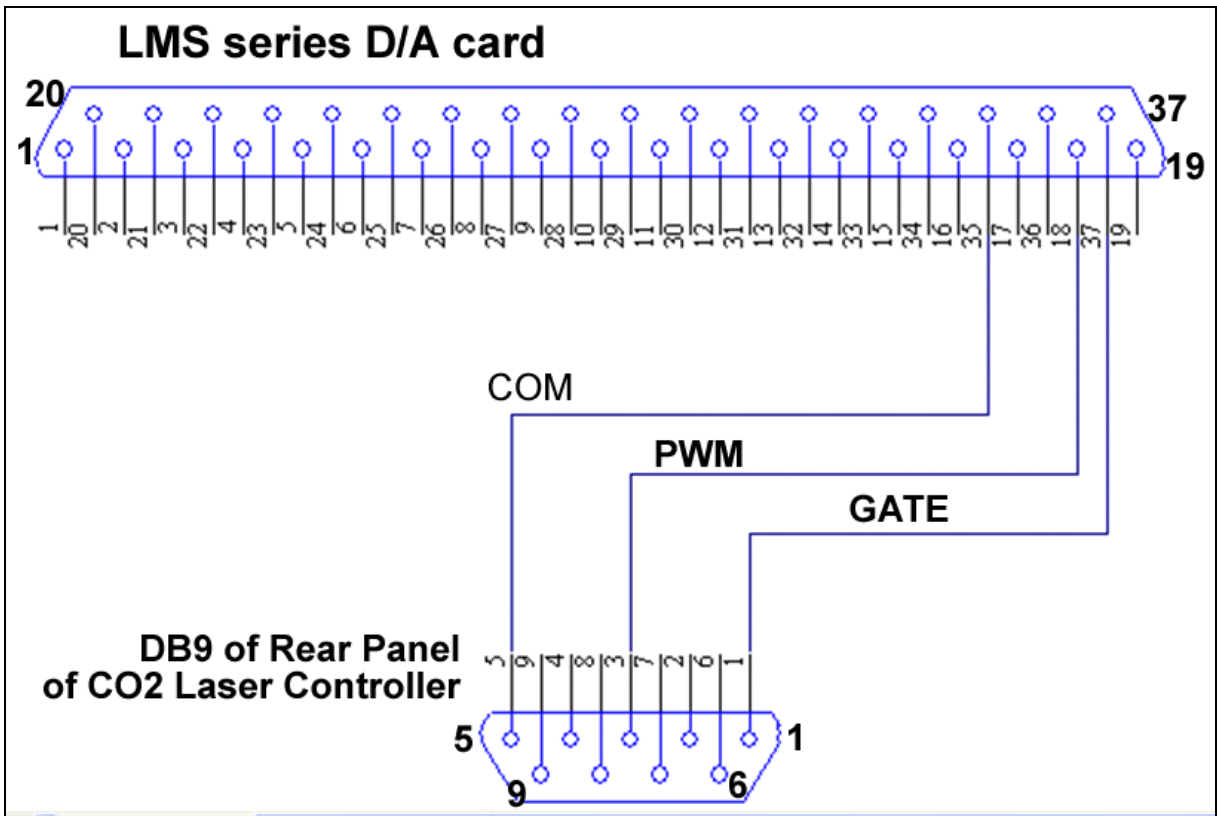

If the customer uses our LMC series D/A cards, the connection should be as follows:

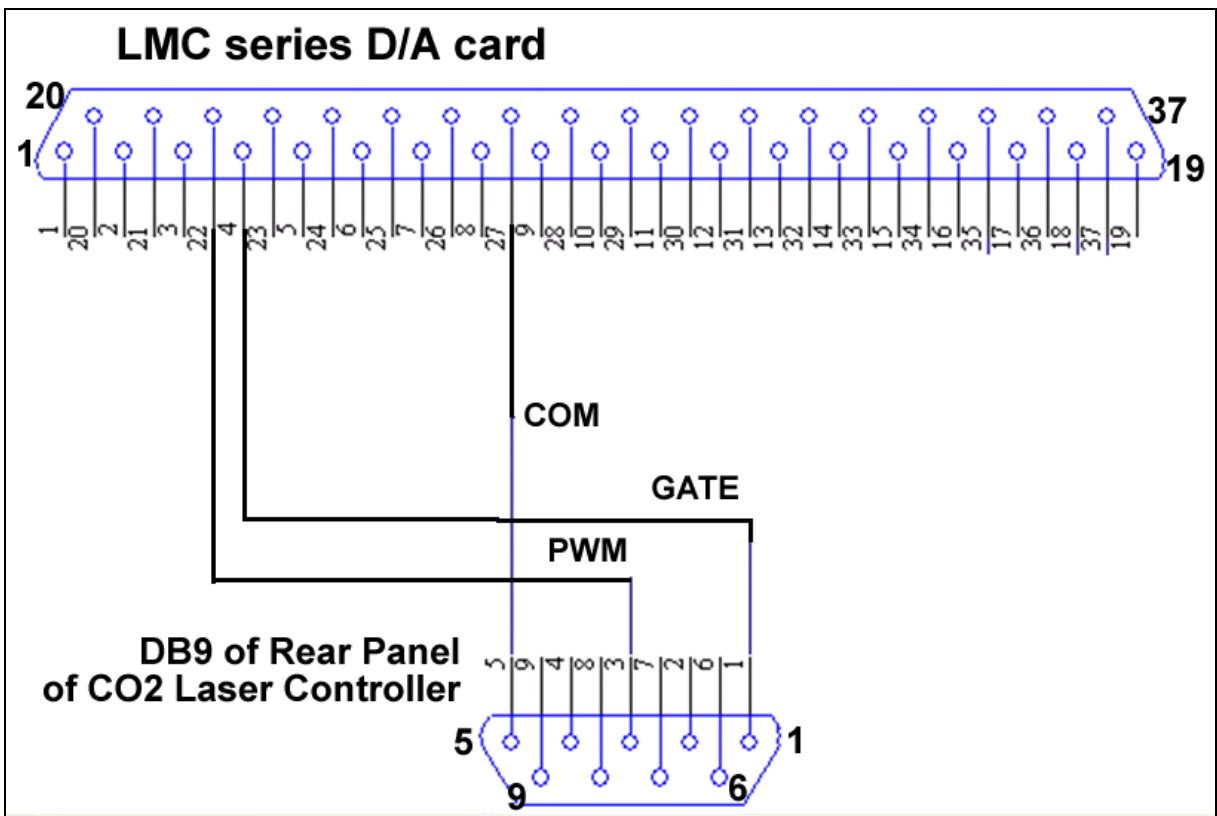

**Cables given with the controller**

1. cable with 3-PIN female connector (K6, electricity input): 3-wires with external white cover. PIN1 (phase, red), PIN2 (neutral, black) & PIN3 (ground, yellow-green)
2. cable with 3-PIN male connector (K7, DC power output to laser). Here it is 48VDC. PIN1 (+48VDC, red), PIN2 (COM, yellow-green), PIN2 (empty)
3. cable with DB9 connector (control input), PIN3 (PWM, red), PIN5 (COM, black), PIN6 & PIN9 (foot switch)
4. cable with DB15 connector (to laser), PIN4 (PWM, red), PIN12 (COM, black)

**Dimension:**

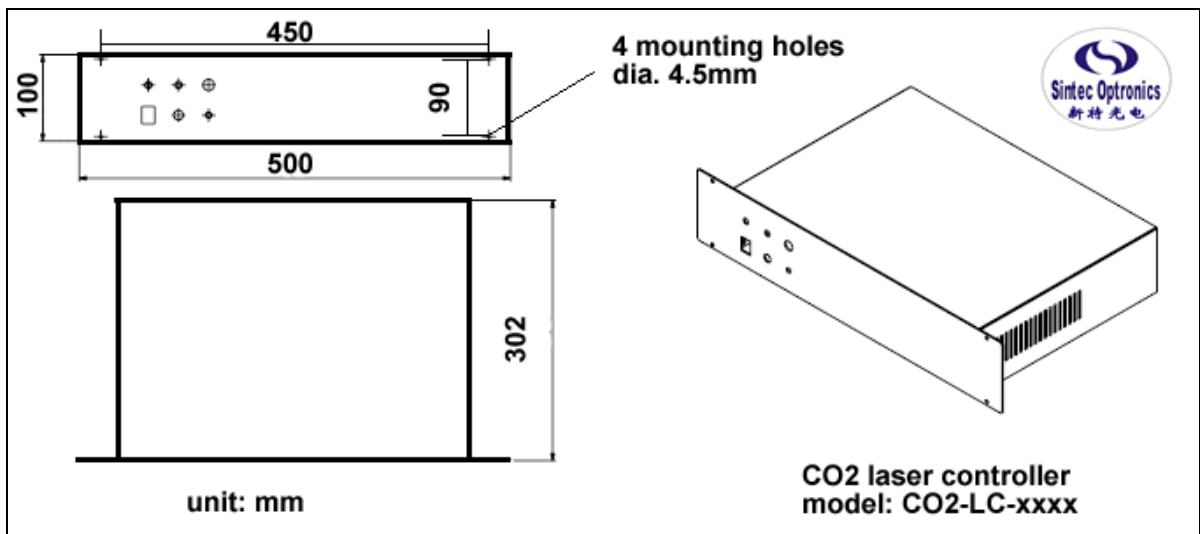

# Sintec Optronics Pte Ltd

We, Sintec Optronics Pte Ltd, are a Singapore-based supplier of a wide range of photonics products (lasers & parts, optical components, and relevant accessories). We provide various high-quality low-price lasers, parts & optics for OEM and end users. The company is managed by experienced professionals with engineering & servicing backgrounds. Our customers range over 32 countries around the world.

## 1. Lasers & Machines

- 1.1 Sealed CW CO2 lasers
- 1.2 CW Nd:YAG laser systems
- 1.3 Diode-pumped YAG lasers
- 1.4 Diode pumped green lasers
- 1.5 Pulse Nd:YAG lasers
- 1.6 High-power diode lasers
- 1.7 Red diode lasers
- 1.8 Diode-pumped green lasers
- 1.9 Laser cutting machines
- 1.10 Laser marking machines
- 1.11 Laser engraving machines

## 2. Optical Components

- 2.1 Focusing lenses
- 2.2 Mirrors & output couplers
- 2.4 Beam expanders
- 2.5 Zoom beam expanders
- 2.6 Beam splitters
- 2.7 Scan mirrors
- 2.8 Scan lenses (f-theta lenses)

## 3. Accessories

- 3.1 Laser lamps (Kr and Xe lamps)
- 3.2 CW and pulse Nd:YAG laser power supply
- 3.3 Diode laser drivers
- 3.4 Laser chillers/heat exchangers
- 3.5 Laser crystals & optical crystals (YAG rods, KTP, BBO, ZnSe etc)
- 3.3 AO & EO Q-switches & drivers
- 3.4 AOMs
- 3.5 Laser power/energy meters
- 3.6 Laser safety goggles
- 3.7 Optical scanners/galvanometers
- 3.8 Motorized or manual adjustable XYZ stages & rotary stages
- 3.9 Vertical translation stages
- 3.10 Mirror mounts, holders, posts & holders
- 3.11 Optical tables
- 3.12 CNC control software
- 3.13 Laser marking heads and marking software
- 3.14 Laser pump chambers

We are a leading company in Singapore to provide quality laser systems & optical components and excellent services at attractive prices. We always try our best to make our products reliable, safe, easy to use, flexible and economical. We believe our continuing advances in technologies will make us the best choice to provide the solutions to make you remain competitive and be a leader in your own field.